

working title: INDUSTRIAN PILZ

AND/  
Walther Ruttmann  
Caspar David Friedrich  
Claude Dias  
Foreigner  
Kraftwerk  
Charles McIlvaine  
John Cage  
Robert Morris  
Leni Riefenstahl  
Rammstein  
Lytle Shaw

image: glass, water, wiper, windshield: trabban  
(still) waiting @ traincrossing

sound: light rain. silent, train approaching but distant  
(out of frame—right)

title: scenario for

sound: train passing: interrupted by

title: (a film

image: shots of countryside from train enroute to Berlin  
intercut with extreme closeups of tracks  
(Walther Ruttmann

title: (an Industrian Pilzibel

image: a landscape, still  
(Caspar David Friedrich

title: noon, c.1822

# BERLIN



POTSDAMER PLATZ ●

115. Noon, c. 1822

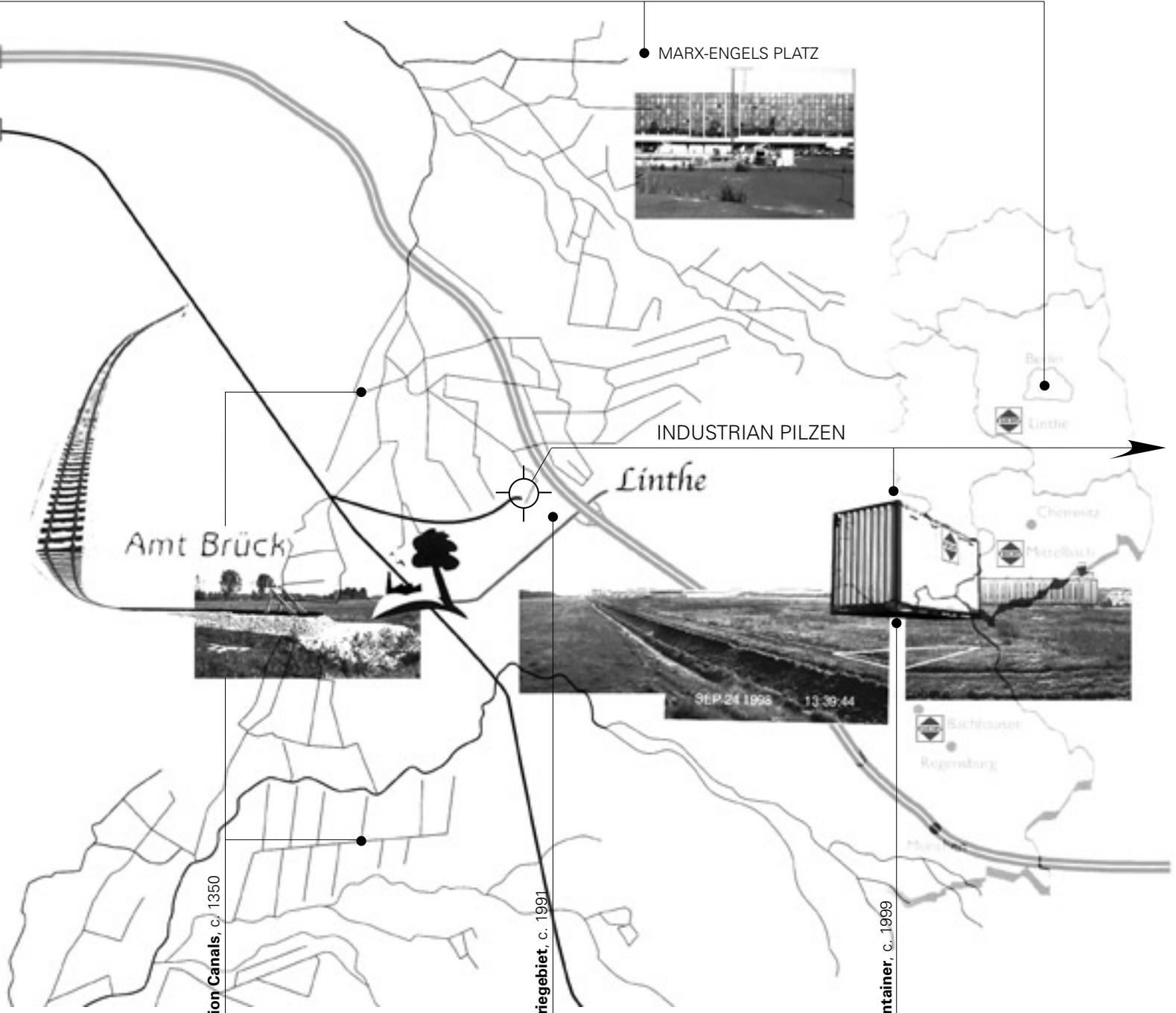

● MARX-ENGELS PLATZ



INDUSTRIAN PILZEN

Amt Brück

Linthe

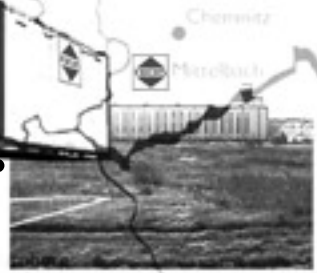

116. Irrigation Canals, c. 1350

117. Industrieregion, c. 1991

118. Pilzcontainer, c. 1999



sound: modem dial and connect

title: Introduction

voice: (young British woman, possibly a newscaster for the BBC?)

Industria is without a pilzfibel of the Industrian species of fungi, among which both edible and poisonous varieties are found. The need of the mycologist, mycophagist and amateur toadstool student is a work giving accurate descriptions of the prominent Industrian toadstools whose edibility has been tested, or whose poisonous qualities have been discerned. The absence of such a work, coupled with the rapid and global proliferation of the Industrian fungi has led to the present work, which seeks to provide guidelines for consumption within greater Industrian landscapes.

image: MRI scan: Interpeduncular Fossa

title: (a grafting of flows within subtopic urbanisations)

image: autacam tracking shot from autobahn nighttime passing Esso petrol station irradiant

title: unexpected subject no. 1

image: Esso station interior. Convenience store.

action: Young East German truck driver being interviewed talks of early apprenticeship as a handwerker in upholstery, how after the Industriegebiet was built his father called him back home to work for the new family Spedition company. And now they drive exclusively for Füchs! Yes life is better now.

sound: piped in through store's sound system:  
"I Want To Know What Love Is"  
Foreigner  
Agent Provocateur  
Wea/Atlantic ASIN: B000002J5Z

claudio dias: I don't know. A bit physical maybe, and not so much idealistic. I can understand it in a certain way but on the other hand my image of what was possible died as well: it's like getting sober, after being drunk a bit.  
(pause).

hmmm...

narrator: (a very excited Swiss-German unemployed border guard):

The body of this work has been assembled from material gathered in the course of the authors' probings along the southwestern reef of Berlin's greater metropolitan area. Here we encountered an isolated yet hardly unique outgrowth of a species of fungi previously unaccounted for in this sparsely populated region of farmland. Growing upon a glacial basin once irrigated by a series of canals cut by the Dutch more than six hundred years ago, this patch is presently fed by Autobahn A9 and the Deutchesbahn Berlin-Belzig train line. Apparently sprouting in the wake of West Germany's absorption of the decaying East German state, this particular patch is now fully developed and ripe for picking. While the conditions observed may be quite familiar to western sensibilities, they do arise in a geographic context absent from the post-war sub-topic development so prevalent in the West. Given the local population's relative unfamiliarity with this species of fungi—and the digestive risks associated with its unbridled and indiscriminate consumption—we embarked immediately upon the fastidious task of compiling the maps, diagrams, and documents necessary for a detailed account of this fungal growth.

John Cage: Where a species is vouched for as edible, it has been personally tested by the authors and their willing undertasters up to eating full meals of it, or at least beyond all doubt as to its safety. Where others have eaten species which they have not had the opportunity to test, their names and opinions are given. When species heretofore under the ban of suspicion are in this volume, for the first time, announced to be edible (there are many of them), personal tests have not been considered sufficient, as indeterminacy might have affected the results. Others, at the writers' request, have eaten of the species until their innocence was fully established. In some cases, where the reputation of the fungi eaten was especially bad, scientists of note have made elaborate and exhaustive physiological tests of their substances, and in every instance confirmed the human testing.

C. McIlvaine: While species which contain deadly poisons are few, their individuals are produced in great number. Nicety in distinguishing their botanic variance from edible species closely resembling them is necessary. No charm will detect the poison. Eating toadstools before their certain identification as belonging to edible species, is neither bravery nor common sense. The amateur should go slow.

image: American standard pressure-assisted flush toilet



FLIEGENPILZ

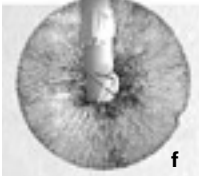

f

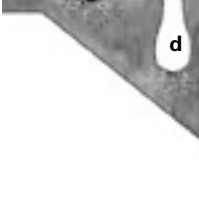

PROGRESSIVE GROWTH OF AGARICS

FIGS. A,B,C,D,E  
FIG. F

STAGES OF DEVELOPMENT OF AN AGARIC  
SPORE PRINT

PLATE III.

PILZCONTAINER

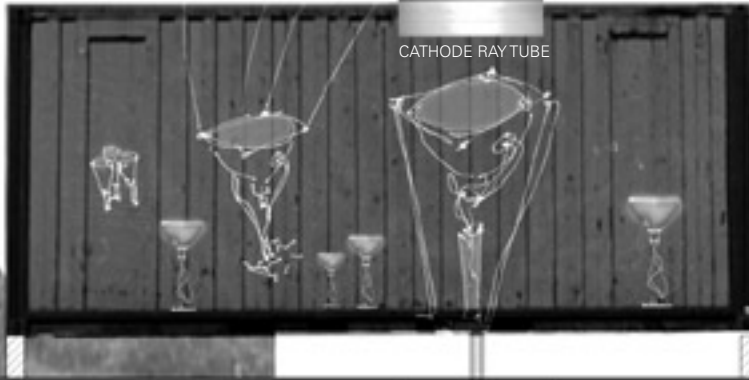

DVD PLAYER

MICROCONTROLLER

DATA CONDUIT

GERMINATION OF INDUSTRIAN SPORIFERA

FIG. A DIGITAL SCANS OF INTERNAL PLANT OPERATIONS  
FIG. B SECTION OF GILL MAGNIFIED  
FIG. C INDUSTRIEGEBEIT

PLATE IV.

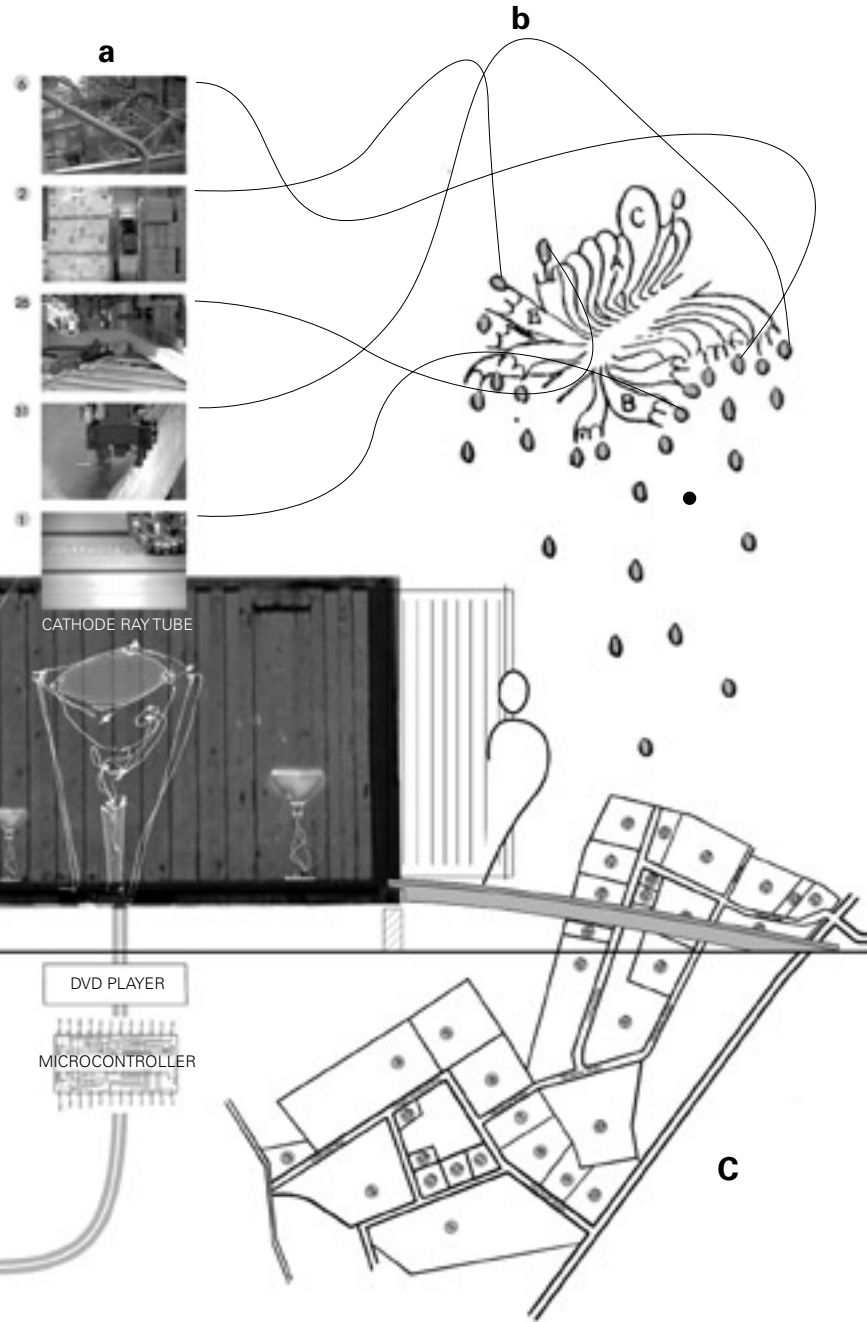

John Cage: After a while she came back and whispered in my ear, "Do you feel alright?" I said, "No, I don't. My throat is burning and I can hardly breathe." I told the others to divide my winnings, that I was folding. I went outside and retched. Vomiting with diarrhea continued for about two hours. Before I lost my will, I told M.C. Richards to call Mother and Dad and tell them not to eat the...

intertitle: Industrian Pilzen

British Newscaster: The beginner at toadstool eating usually expects commendation for bravery, and fearfully watches for hours the coming of something dreadful. Indigestion from any other cause is always laid to the traditional enemy, fright ensues, a physician is called, the scare spreads and a pestilential story of "Severe Poisoning by Toadstools," gets into the newspapers. The writers have traced many such publications to imprudences in eating, with which Industrian toadstools had nothing to do.

image: corporate headshots of Füchs plant managers

Robert Morris: Let us clear away the rubbish and superstition that have so long obscured the straight path to a knowledge of edible Industrial toadstools. Let us bear in mind that a mushroom is a toadstool and a toadstool is a mushroom—the terms are interchangeable. If toads ever occupied the one-legged seat assigned them from time immemorial, they have learned in this enlightened age that the ground is much more reliable, and so squat upon it, except when exercising their constitutional right to hop.

image: Leni Riefenstahl diver

intertitle: Olympia, 1937

image: scuba-cam views of sub-tropical sea turtles, most likely appropriated from the Discovery Channel, not Leni Riefenstahl

title: A GUIDE FOR STUDENTS

sound: /schizogeo/mp3/rammstein: Asche Zu Asche

narrator: To catch a fish one must know more than the fish; to find Industrian toadstools one must know their season and habitats. They are propagated by their spores and from their mycelium—that web-like growth which is the result of spore germination. The spores of ground-growing kinds, when

shed upon the ground, are washed by flows of capital along the natural conduits of social drainage; therefore, when a specimen of one of these kinds is found, it is well to look up and down the watershed, and follow it. Good reward will usually come of it. Few fungi are strictly solitary.

sound: faint humming of the autobahn, distant

narrator: Each species has its favourite habitat, and will thrive best upon it. There are few things under the sun upon which this fungi will not grow. Their mission is particularly directed toward converting decaying matter, or matter which has accomplished its own work in one direction, into usefulness in another.

image: Marx-Engels Platz

title: vacancy

narrator: When they feed on dead substances they are called saprophytes. When their support is derived from living tissue, parasites.

image: Potsdamerplatz

intertitle: erasure

image: Aerial view from a hot air balloon looking down on the Belziger Landschaftswiesen, a curious net work of cuts into the land is evident.

title: THE MYCELIUM

sound: modem dial and connect

narrator: If one carefully removes the toadstool from whatever it is growing upon, and with it a portion from which it springs, a curious network of tentacular strands is discernible. Fine as the delicate spinning of the spider, this is the mycelium from which the toadstool grew. In many instances it extends across the earth to considerable distances, taking possession of large territory and occupying considerable bandwidth.

image: coptercam tracking shot looking down along the New Jersey Turnpike...

narrator: This mycelium is but a thread-like mass of simple cells joined together at their ends and interlacing in a way a thousand-fold more intricate than a Chinese puzzle. Nothing in its structure indicates what its special product will be. The fun-

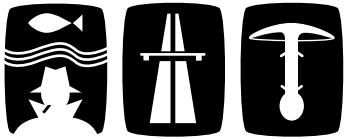

A9

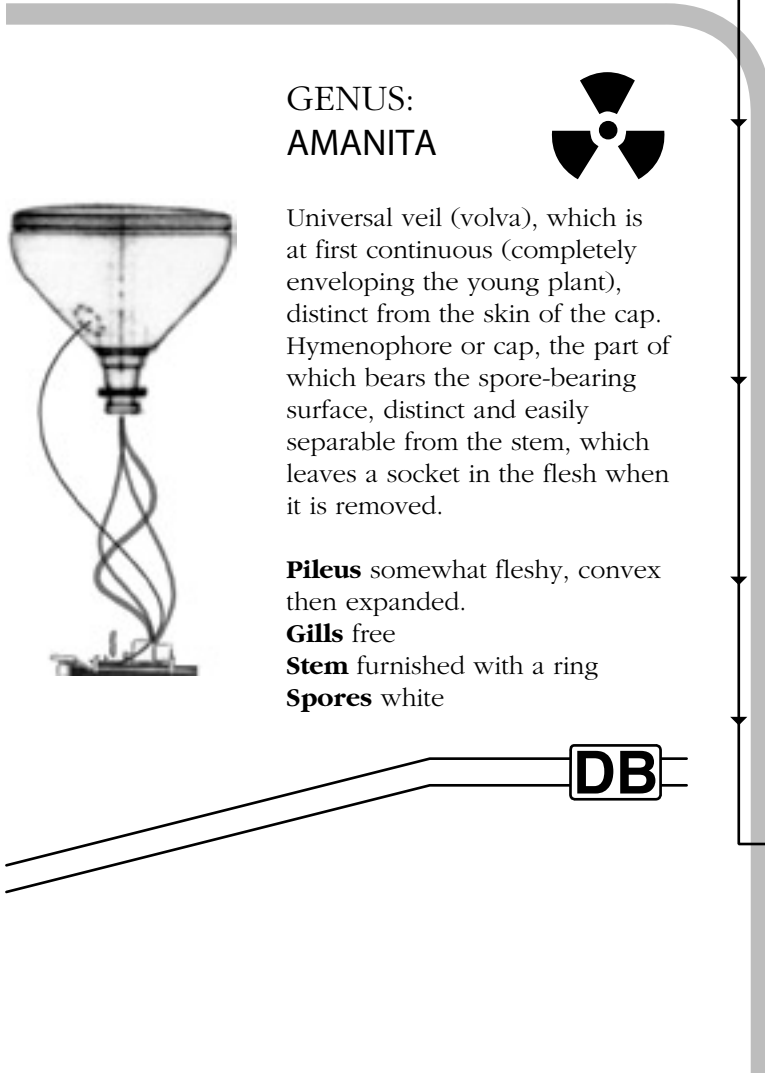
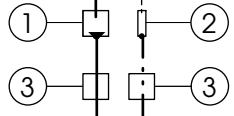
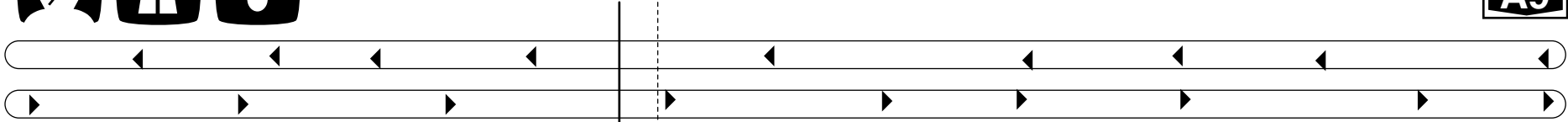

GENUS:  
AMANITA

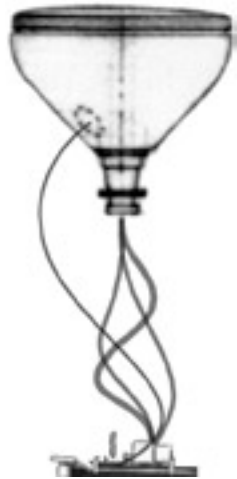

Universal veil (volva), which is at first continuous (completely enveloping the young plant), distinct from the skin of the cap. Hymenophore or cap, the part of which bears the spore-bearing surface, distinct and easily separable from the stem, which leaves a socket in the flesh when it is removed.

**Pileus** somewhat fleshy, convex then expanded.

**Gills** free

**Stem** furnished with a ring

**Spores** white

**COMPONENTS**

1. EPDM Road Tube w/ Low Voltage Air Switch
2. Shotgun Microphone
3. Line Amplifier
4. Audio Amplifier
5. Audio Speakers
6. Basic Stamp Programmable Microcontroller
7. DVD Players
8. Cathode Ray Tubes

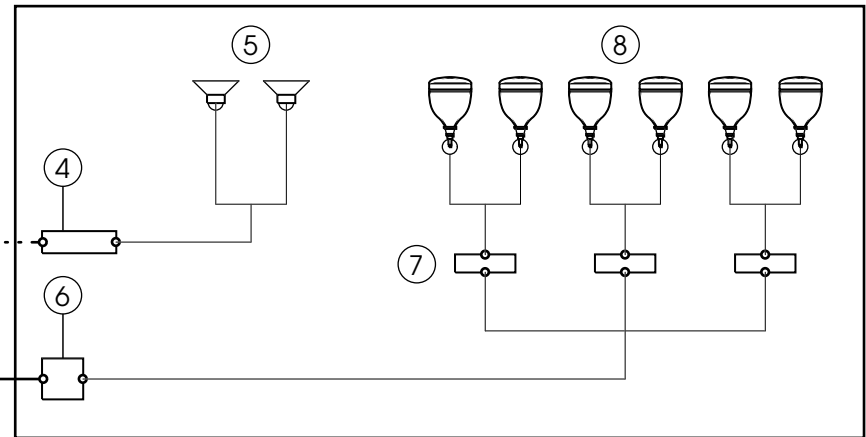

**PILZCONTAINER**



gus which is plucked from it is in all its parts simply a mass of these threads—cells strung together, interlacing and ramifying.

image: VW Jetta wrapped around a tree along a nineteenth century East German rural allee

sound: *fun, fun auf der autobahn!*

narrator: When the season favours, the mycelium—which has, winter and summer and from year to year, lived its hidden life, or has sprung from a germinating spore—develops a number of its cells in a minute knob, small as a pin head. At this point the cells make special growth efforts to bring themselves within the favoring influences of heat, moisture, desire and venture capital; this tiny knob labors within itself, producing cell after cell, which takes shape and function for the future toadstool's expansion.

image: mushroom cloud expanding vertically

narrator: As it rapidly enlarges it pushes its way toward the surface of public consciousness, becomes more or less egg-shaped in this stage of its growth, and if cut in half longitudinally and examined, it will display what it is going to be when it grows up.

image: longitudinal sectional cut of cathode ray tube

Lyle Shaw: The greatest care has been taken to secure illustrations correct in every botanical detail. With few exceptions the colored figures were drawn and painted by the writers. To obtain this important feature the requirements of art have frequently been sacrificed. An artist can make a picture of a toadstool; the mycologist must guide his brush or pencil in the making of a correct presentation.

image: fliegenpilz

title: fly (ing mushroom)

/AND: Finally, we have kept in view throughout the work the needs of the mycophagists. They are not pot-hunters; they care much less for the physical pleasure of the appetite than for the close study of *Industria* that their inclination leads them into. Some day the delights of an *Industrian Pilz* hunt along lush pastures and rich woodlands will take the rank of the gentlest craft among those of hunting, and may perchance find its own Izaak Walton.